



HCP PUMP

FILE NO PC-M-E5-80AGN21.51

PUMP PERFORMANCE CURVES

MODEL	80AGN21.5					DATE:	2011.12	
	STANDARD SPECIFICATION					REFERENCE SPECIFICATION		
FREQUENCY	50					Hz		
DISCHARGE	3	inch	/	80	mm			
OUTPUT	2	HP	/	1.5	kW	HP	kW	
HEAD	9					M		
CAPACITY	0.5					m ³ /min		
PHASE/VOLTAGE	1	φ	220 V	230 V	240 V		φ	V
RATED CURRENT		10.4 A	10.0 A	9.8 A				A
POLE / R.P.M.	2	P	/	2800	R.P.M.			
START METHOD	DIRECT							
INSULATION CLASS	B							
REMARK								

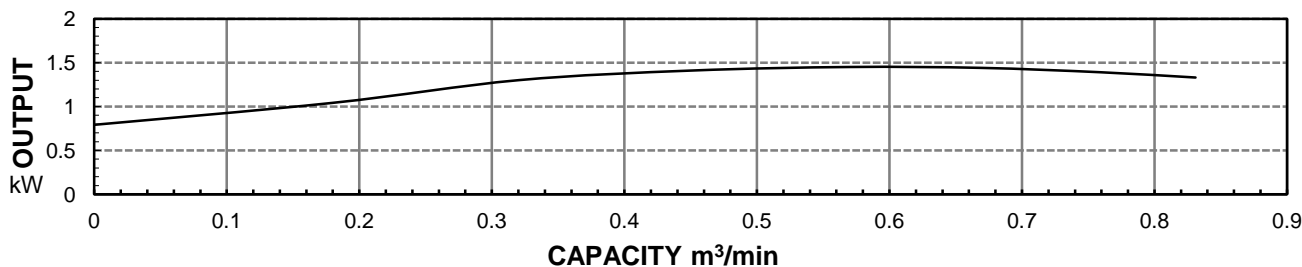
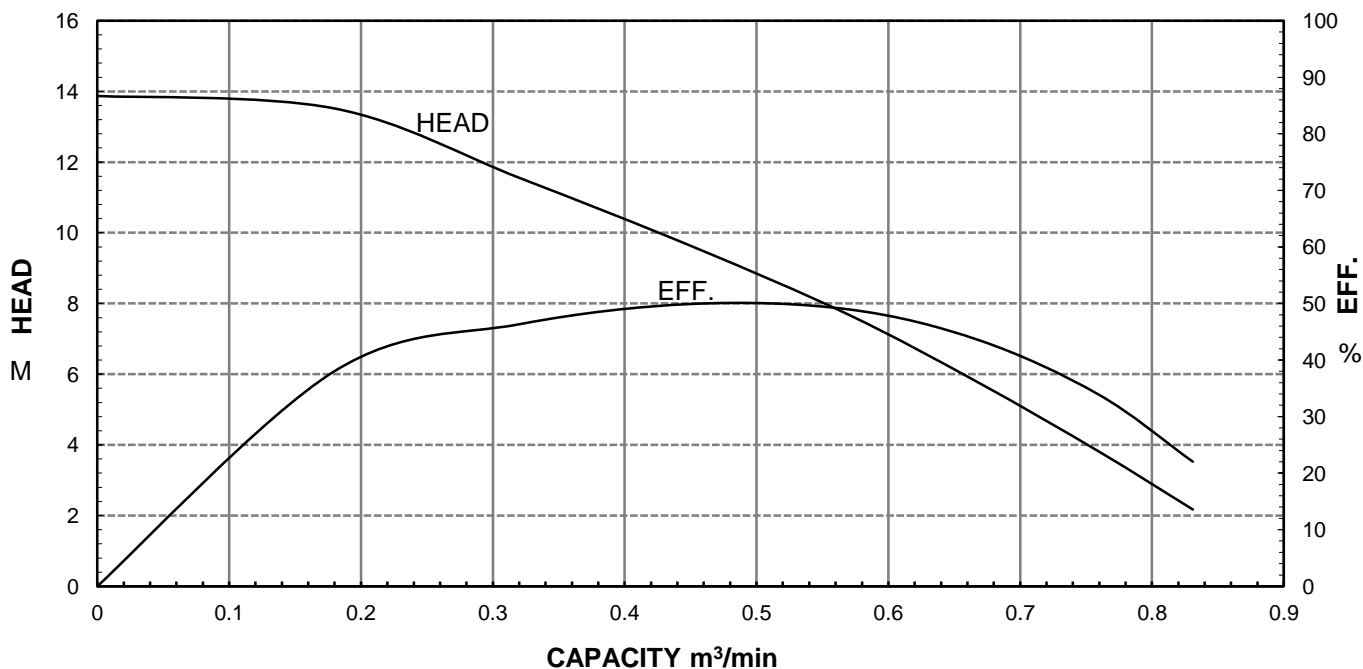

HCP PUMP MANUFACTURER CO.,LTD.



HCP PUMP

FILE NO PC-M-E5-80AGN21.53

PUMP PERFORMANCE CURVES

MODEL	80AGN21.5				DATE:	2011.12
	STANDARD SPECIFICATION				REFERENCE SPECIFICATION	
FREQUENCY	50			Hz		
DISCHARGE	3	inch	/	80	mm	
OUTPUT	2	HP	/	1.5	kW	HP kW
HEAD	9			M		
CAPACITY	0.5			m ³ /min		
PHASE/VOLTAGE	3 φ	230 V	380 V	400 V	415 V	φ V
RATED CURRENT		6.1 A	3.6 A	3.5 A	3.4 A	A
POLE / R.P.M.	2	P	/	2800	R.P.M.	
START METHOD	DIRECT					
INSULATION CLASS	B					
REMARK						

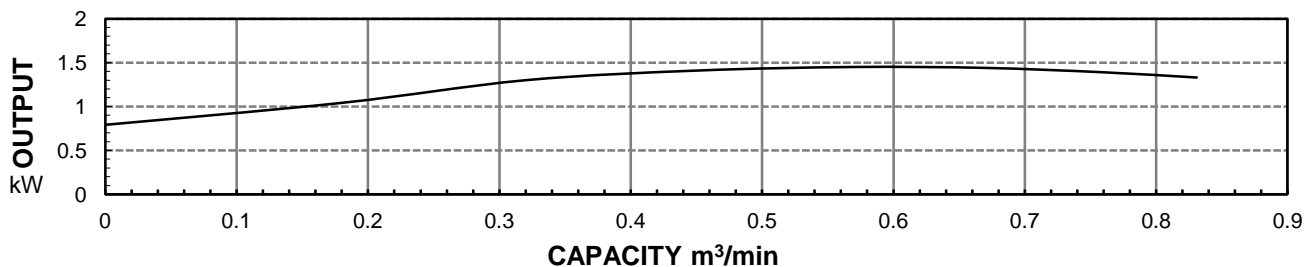
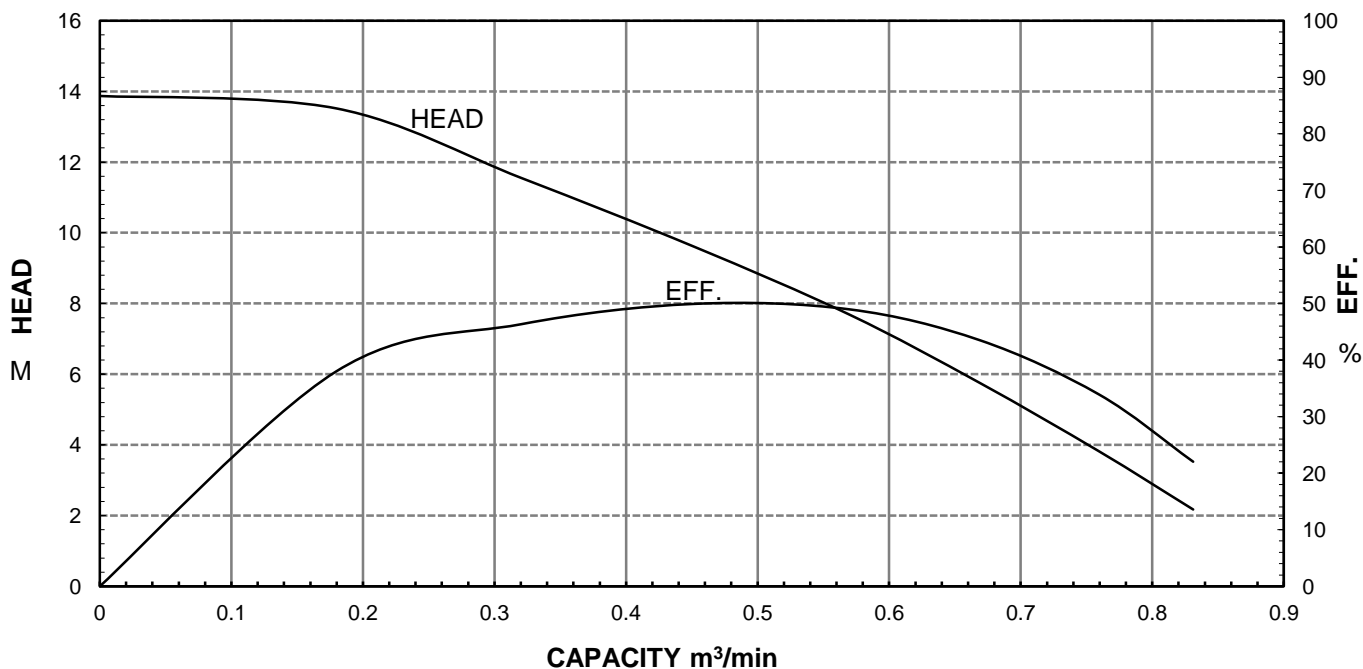

HCP PUMP MANUFACTURER CO.,LTD.

HCP PUMP

DIMENSIONAL DRAWING

No:DE-80AGN21.5

Date:2011-01

MODEL: 80AGN21.5;80AGN22.2;80AGN23.7

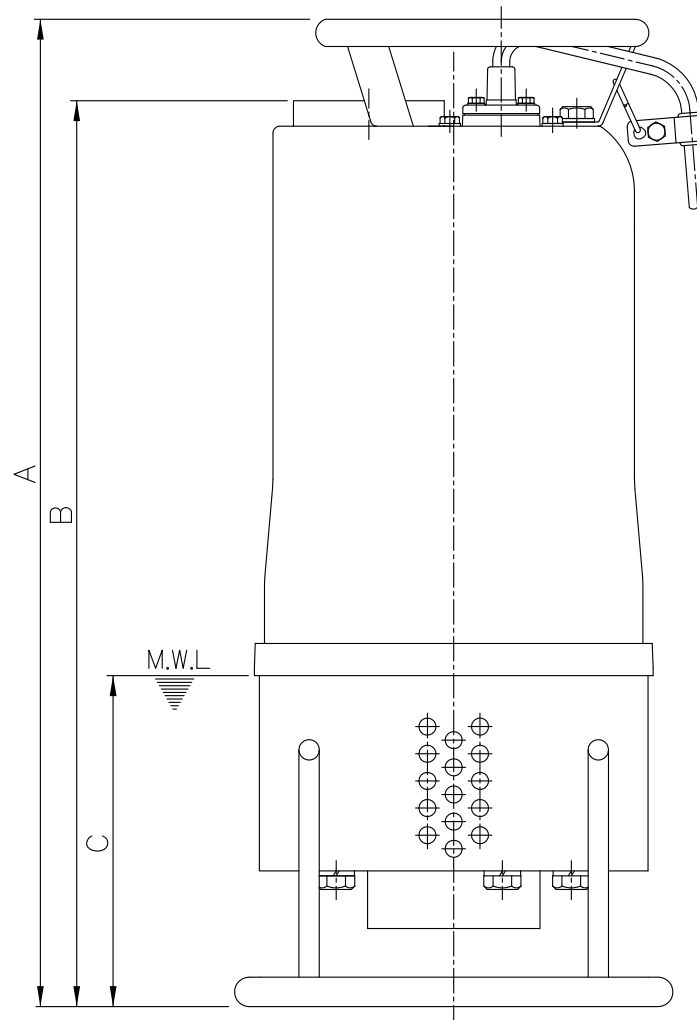
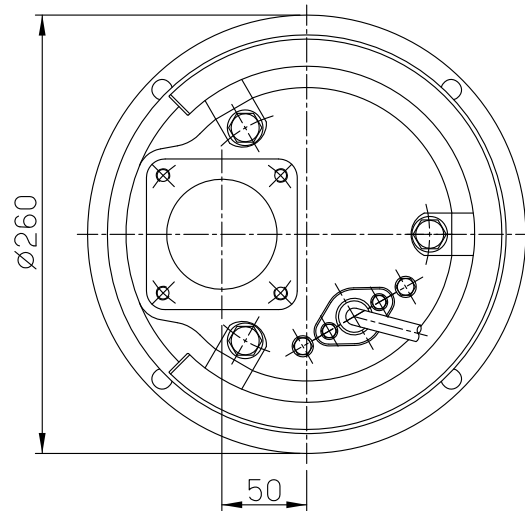

MODEL	A	B	C
80AGN21.5	547(592)	499(544)	195
80AGN22.2	547(622)	499(574)	195
80AGN23.7	577	529	195

M.W.L: Minimun water level

Remark:()Dimensions in 1 \varnothing

MODEL:80AGN21.5;80AGN22.2 1Ø

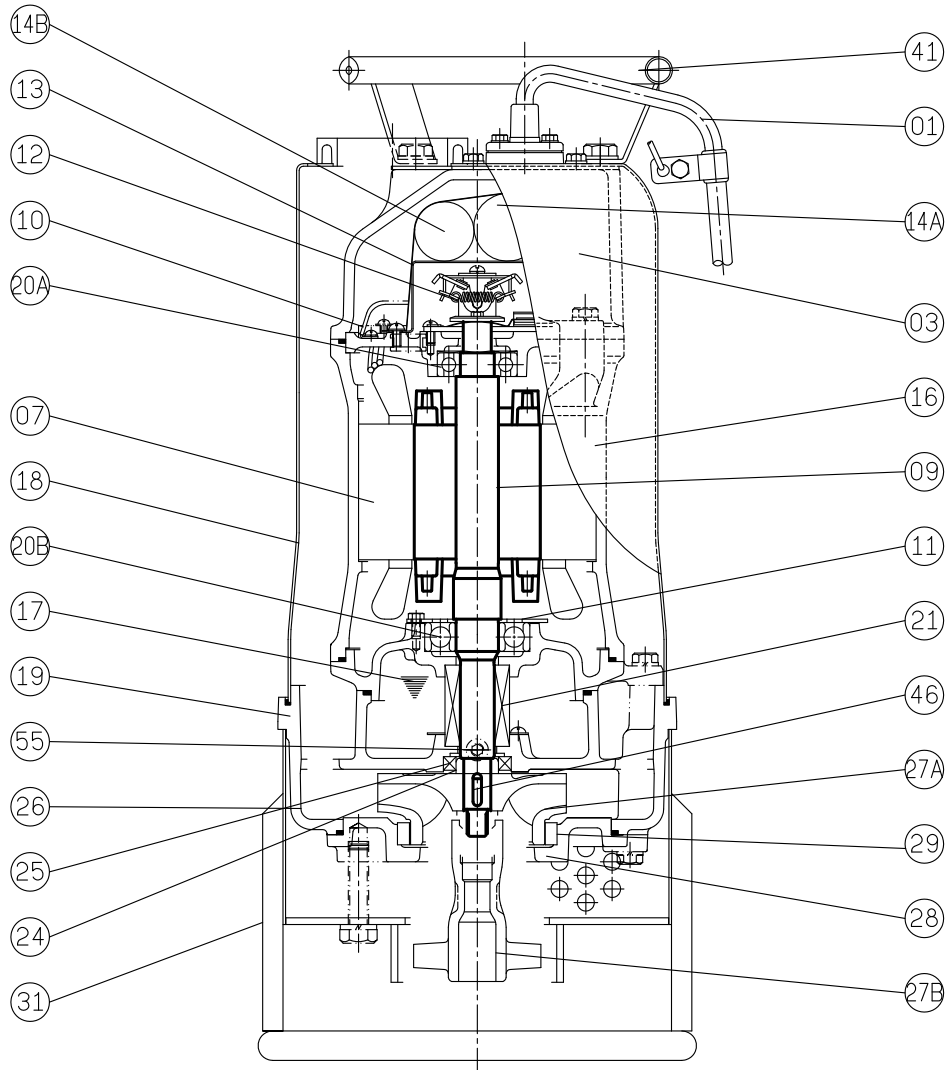

No.	Part name	Material	QTY	Remark
01	Cable		1	VCT/H07RN-F UL / CSA
03	Upper cover	FC-200	1	
06	Bracket	FC-200	1	
07	Stator		1	
09	Shaft(with Rotor)	SUS403	1	
10	Auto-cut		1	
11	Bearing fixer	SPCC	1	
12	Centrifugal switch		1	
13	Centrifugal switch cover		1	
14A	Capacitor		1	
14B	Start capacitor		1	
16	Motor frame	FC-200	1	
17	Lubricant	Turbine oil #32	1	
18	Out cover	SUS304	1	
19	Bearing bracket	FC-200	1	

No.	Part name	Material	QTY	Remark
20A	Upper bearing		1	
20B	Lower bearing		1	
21	M. seal	CA VS CE SIC VS SIC	1	
24	Oil seal bush	SUS403	1	
25	Oil seal	NBR	1	
26	Casing	FC-200	1	
27A	Impeller	HiCr	1	
27B	Agitator	FCD700	1	
28	Casing cover	FC-200	1	
29	Wear ring	HiCr	1	
31	Strainer	SUS304	1	
41	Handle	SUS304	1	
46	Impeller key	SUS304	1	
47	Packing (1 set)		1	
55	Oil plug		1	

MODEL:80AGN21.5;80AGN22.2;80AGN23.7 3Ø

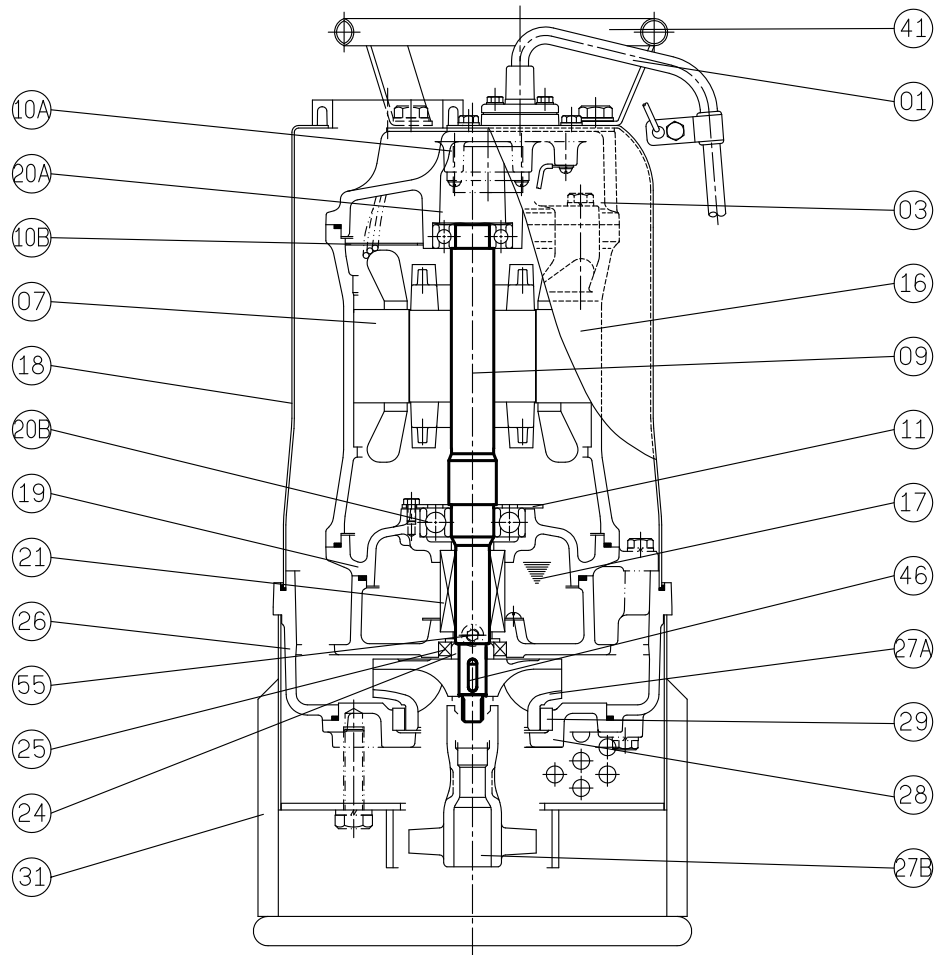

No.	Part name	Material	QTY	Remark
01	Cable		1	VCT/ H07RN-F UL / CSA
03	Upper cover	FC-200	1	
04	Cable base cover	SUS304	1	
09	Shaft(with Rotor)	SUS403	1	
10A	Auto-cut		1	
10B	Auto-cut plate		1	
11	Bearing fixer	SPCC	1	
16	Motor frame	FC-200	1	
17	Lubricant	Turbine oil #32	1	
18	Out cover	SUS304	1	
19	Bearing bracket	FC-200	1	
20A	Upper bearing		1	
20B	Lower bearing		1	
21	M. seal	CA VS CE SIC VS SIC	1	
24	Oil seal bush	SUS403	1	

No.	Part name	Material	QTY	Remark
25	Oil seal	NBR	1	
26	Casing	FC-200	1	
27A	Impeller	HiCr	1	
27B	Agitator	FCD700	1	
28	Casing cover	FC-200	1	
29	Wear ring	HiCr	1	
31	Strainer	SUS304	1	
41	Handle	SUS304	1	
46	Impeller key	SUS304	1	
47	Packing (1 set)		1	
55	Oil plug	SUS304	1	